

TIPPER SAFETY STAND INSTRUCTIONS

PART NO: TQA-SAFE-01

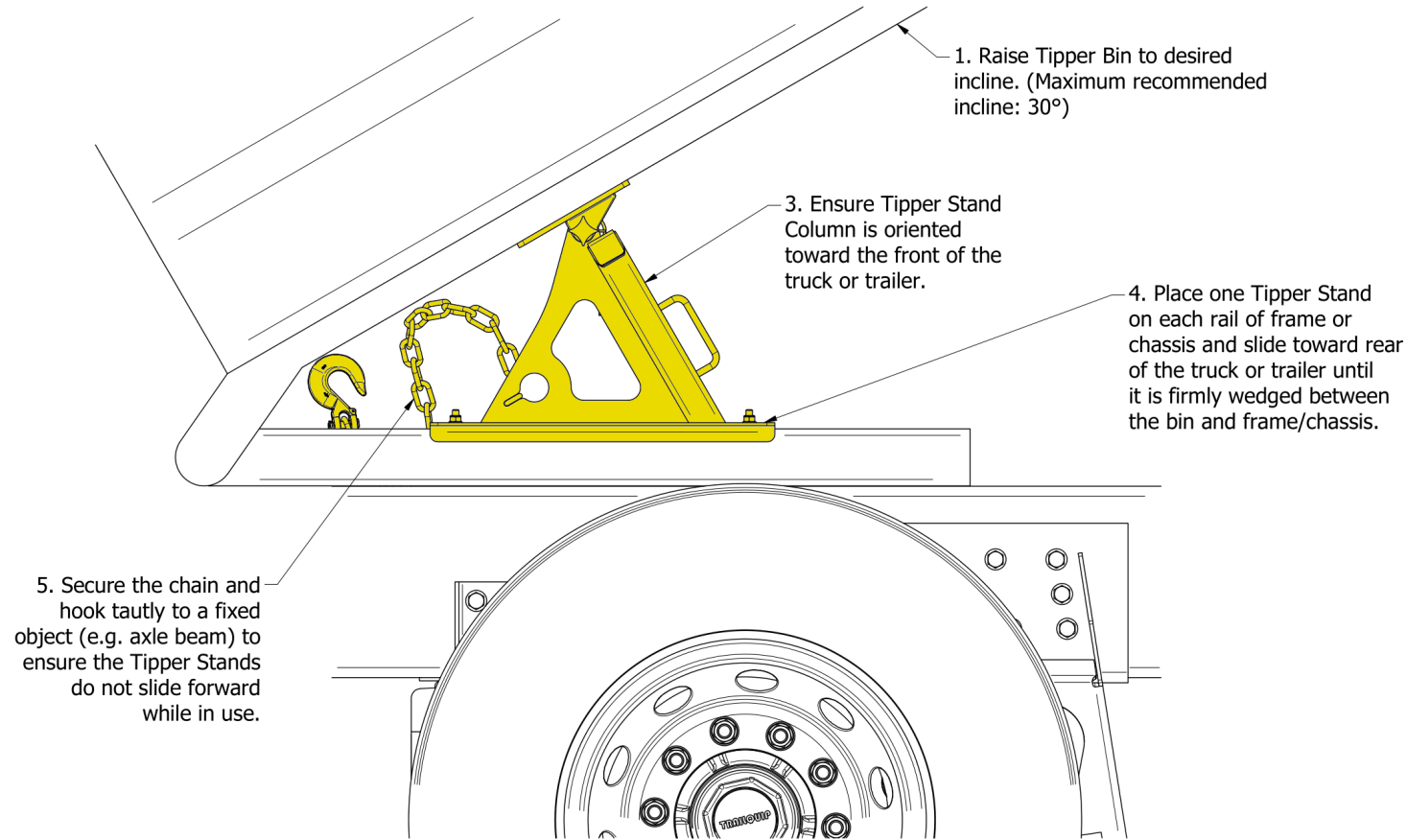

1. Raise Tipper Bin to desired incline. (Maximum recommended incline: 30°)

3. Ensure Tipper Stand Column is oriented toward the front of the truck or trailer.

4. Place one Tipper Stand on each rail of frame or chassis and slide toward rear of the truck or trailer until it is firmly wedged between the bin and frame/chassis.

5. Secure the chain and hook tautly to a fixed object (e.g. axle beam) to ensure the Tipper Stands do not slide forward while in use.

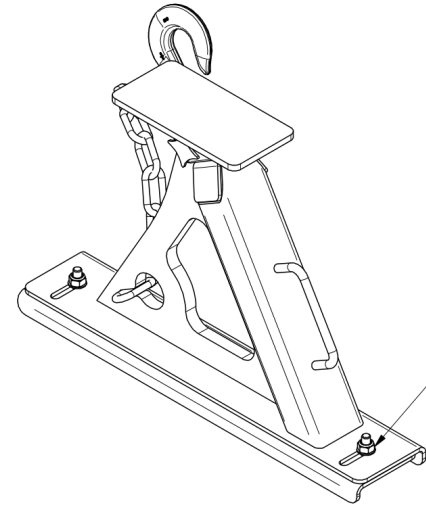

2. Adjust foot width to suit tipper frame or chassis.

Secure the nut firmly prior to use.

WARNING:

- Tipper bin **MUST BE EMPTY** while Tipper Stands are in use.
- Tipper Stands must be used as a pair.
- Ensure that Clevis and Lynch Pins are Secure prior to use.
- Each Tipper Stand has a **MAXIMUM** load rating of 5,000kg (10,000kg per pair).
- Stand clear whilst releasing hydraulic pressure from the cylinder, as the Tipper Stands are loaded.
- Ensure there is no movement of bin before commencing work underneath.
- Always Inspect Tipper Stands for cracks or damage prior to use. Do Not use if any damage is suspected.

**AIR BRAKE SERVICES
TRAILQUIP**

1898 Ipswich Rd, Rocklea QLD, 4106, Australia
www.abstrailquip.com
ABN: 89 126 053 521
T.: (07) 3274 6046
F.: (07) 3274 6048

REV	DESCRIPTION OF CHANGE	DATE	INITIALS	APPROVED

Copyright © ABS Trailquip Pty Ltd

ALL RIGHTS RESERVED. THE INFORMATION IN THIS DOCUMENT IS SUBJECT TO TERMS AND CONDITIONS OF THE AGREEMENT OR CONTRACT UNDER WHICH THE DOCUMENT WAS SUPPLIED TO THE RECIPIENT'S ORGANISATION. NO INFORMATION IN THIS DOCUMENT OR PART OF THIS DOCUMENT SHALL BE:
(A) DISCLOSED OUTSIDE RECIPIENT'S OWN ORGANISATION
(B) REPRODUCED OR TRANSMITTED IN ANY WAY OR STORED IN ANY RETRIEVAL SYSTEM WITHOUT PRIOR WRITTEN CONSENT OF ABS TRAILQUIP PTY LTD.

MANUFACTURING TOLERANCES	
FABRICATION	0 - 500: +0,-1
	501 - 2000: +0,-2
	2001 - 5000: +0,-2
	> 5000: +0,-3
DRILL HOLE	6 - 12 MM: +0,2,-0
	13 - 20 MM: +0,3,-0
	20 - 26 MM: +0,3,-0
	26 - 39 MM: +0,4,-0
MACHINING	0 = +/- 0.5MM
	0.0 = +/- 0.1MM
	0.00 = +/- 0.05MM

DRAWN	WW
CHECKED	
MFG	
APPROVED	
SHEET 1 OF 1	

1/06/2021

SIZE
A3



PROJECT / JOB

SAFETY

TITLE
Tipper Safety Stand Instructions

SCALE
1/8

PART NUMBER
TQA-SAFE-01